

Introduction

This document provides safety and installation information for the Keithley ADP-5037 50-pin to 37-pin cable adapter.

Description

The ADP-5037 consists of a ribbon cable having a 50-pin female header connector at one end and a 37-pin male D connector—mounted in a small box—at the other end. The ADP-5037 interfaces digital I/O of certain boards with an SRA-01 digital I/O module accessory or an ERA-01 relay accessory. It interfaces either directly or in combination with additional interface accessories.

You connect the ADP-5037 to an SRA-01 or an ERA-01 via a C1800 or S1800 cable.

Safety summary

WARNING **This accessory is not intended for use in circuits carrying voltages in excess of 30V RMS, 42.4V peak, or 60VDC.**

Read and follow the “Safety Precautions” discussed at the end of this manual.

This product is intended for use by qualified personnel who recognize shock hazards and are familiar with the safety precautions required to avoid possible injury. Read the operating and safety information carefully before using the product.

Installation

CAUTION **Ensure that the computer power is turned OFF before installing the ADP-5037. Connecting the ADP-5037 to the computer while the power is ON can damage your computer, the accessory, or both.**

Figure 1 shows you how to use the ADP-5037 to interface the following boards to an SRA-01 or ERA-01 accessory: the KPCI-PIO96, the PIO-96J, the KPCI-3107, the KPCI-3108, or the KPCI-3160.

Figure 1
ADP-5037 interface connections

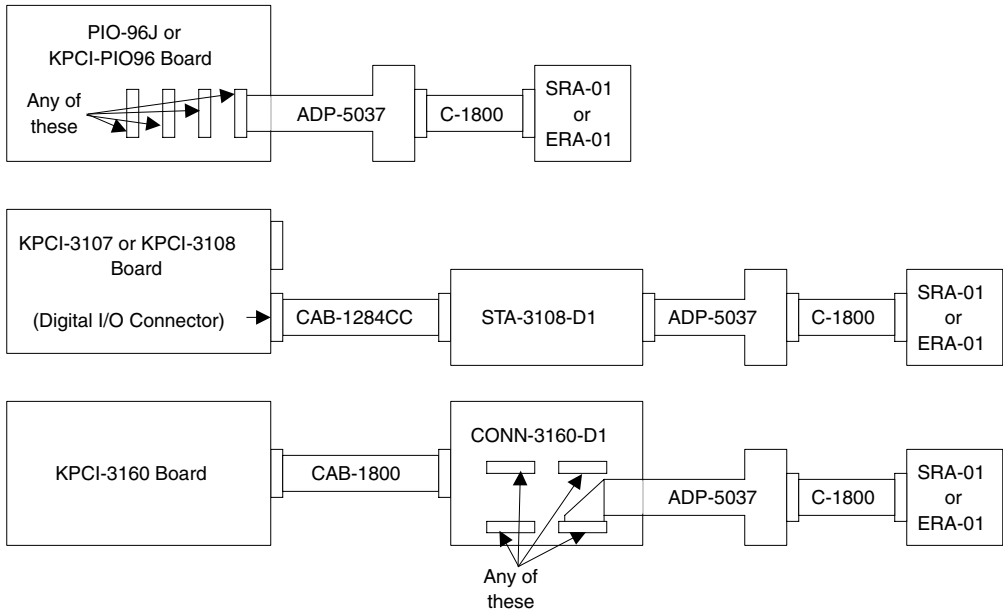

Table 1 shows the pin-to-pin correspondence between the 50-pin header connector and the 37-pin D connector of the ADP-5037.

Table 1
Pin-to-pin correspondence between the ADP-5037 connectors

Pins of the 50-pin header		Pins of the 37-pin D connector
Even-numbered pins	Odd-numbered pins	
	1	30
	3	31
	5	32
	7	33
	9	34
	11	35
	13	36
	15	37
	17	22
	19	23
	21	24
	23	25
	25	26
	27	27
	29	28
	31	29
	33	3

Table 1 (Continued)
Pin-to-pin correspondence between the ADP-5037 connectors

Pins of the 50-pin header		Pins of the 37-pin D connector
Even-numbered pins	Odd-numbered pins	
	35	4
	37	5
	39	6
	41	7
	43	8
	45	9
	47	10
	49	20
2		11
All other even-numbered pins (4, 6, 8, ... 48, 50)		No connections

Safety Precautions

The following safety precautions should be observed before using this product and any associated instrumentation.

This product is intended for use by qualified personnel who recognize shock hazards and are familiar with the safety precautions required to avoid possible injury. Read the operating information carefully before using the product.

The types of product users are:

Responsible body is the individual or group responsible for the use and maintenance of equipment, for ensuring that the equipment is operated within its specifications and operating limits, and for ensuring that operators are adequately trained.

Operators use the product for its intended function. They must be trained in electrical safety procedures and proper use of the instrument. They must be protected from electric shock and contact with hazardous live circuits.

Maintenance personnel perform routine procedures on the product to keep it operating, for example, setting the line voltage or replacing consumable materials. Maintenance procedures are described in the manual. The procedures explicitly state if the operator may perform them. Otherwise, they should be performed only by service personnel.

Service personnel are trained to work on live circuits, and perform safe installations and repairs of products. Only properly trained service personnel may perform installation and service procedures.

Exercise extreme caution when a shock hazard is present. Lethal voltage may be present on cable connector jacks or test fixtures. The American National Standards Institute (ANSI) states that a shock hazard exists when voltage levels greater than 30V RMS, 42.4V peak, or 60VDC are present. **A good safety practice is to expect that hazardous voltage is present in any unknown circuit before measuring.**

Users of this product must be protected from electric shock at all times. The responsible body must ensure that users are prevented access and/or insulated from every connection point. In some cases, connections must be exposed to potential human contact. Product users in these circumstances must be trained to protect themselves from the risk of electric shock. If the circuit is capable of operating at or above 1000 volts, **no conductive part of the circuit may be exposed.**

Do not connect switching cards directly to unlimited power circuits. They are intended to be used with impedance limited sources. NEVER connect switching cards directly to AC mains. When connecting sources to switching cards, install protective devices to limit fault current and voltage to the card.

Inspect the connecting cables, test leads, and jumpers for possible wear, cracks, or breaks before each use.

For maximum safety, do not touch the product, test cables, or any other instruments while power is applied to the circuit under test. ALWAYS remove power from the entire test system and discharge any capacitors before: connecting or disconnecting cables or jumpers, installing or removing switching cards, or making internal changes, such as installing or removing jumpers.

Do not touch any object that could provide a current path to the common side of the circuit under test or power line (earth) ground. Always make measurements with dry hands while standing on a dry, insulated surface capable of withstanding the voltage being measured.

The instrument and accessories must be used in accordance with its specifications and operating instructions or the safety of the equipment may be impaired.

Do not exceed the maximum signal levels of the instruments and accessories, as defined in the specifications and operating information, and as shown on the instrument or test fixture panels, or switching card.

When fuses are used in a product, replace with same type and rating for continued protection against fire hazard.

Chassis connections must only be used as shield connections for measuring circuits, NOT as safety earth ground connections.

If a  screw is present, connect it to safety earth ground using the wire recommended in the user documentation.

The  symbol on an instrument indicates that the user should refer to the operating instructions located in the manual.

The  symbol on an instrument shows that it can source or measure 1000 volts or more, including the combined effect of normal and common mode voltages. Use standard safety precautions to avoid personal contact with these voltages.

The **WARNING** heading in a manual explains dangers that might result in personal injury or death. Always read the associated information very carefully before performing the indicated procedure.

The **CAUTION** heading in a manual explains hazards that could damage the instrument. Such damage may invalidate the warranty.

Instrumentation and accessories shall not be connected to humans.

Before performing any maintenance, disconnect the line cord and all test cables.

To maintain protection from electric shock and fire, replacement components in mains circuits, including the power transformer, test leads, and input jacks, must be purchased from Keithley Instruments. Standard fuses, with applicable national safety approvals, may be used if the rating and type are the same. Other components that are not safety related may be purchased from other suppliers as long as they are equivalent to the original component. (Note that selected parts should be purchased only through Keithley Instruments to maintain accuracy and functionality of the product.) If you are unsure about the applicability of a replacement component, call a Keithley Instruments office for information.

To clean an instrument, use a damp cloth or mild, water based cleaner. Clean the exterior of the instrument only. Do not apply cleaner directly to the instrument or allow liquids to enter or spill on the instrument. Products that consist of a circuit board with no case or chassis (e.g., data acquisition board for installation into a computer) should never require cleaning if handled according to instructions. If the board becomes contaminated and operation is affected, the board should be returned to the factory for proper cleaning/servicing.